

PCIMS – Peroxide Chemical Ionization Mass Spectrometer

Daniel W. O'Sullivan, PI

Brian G Heikes, co-PI

The measurement of gas phase peroxide species, H_2O_2 and CH_3OOH , contribute to our scientific understanding of the photochemistry of trace gases and particles prior to and after their transport and processing through deep convective clouds. The PCIMS instrument used to make these measurements in the DC3 mission is new and this will be its first use in an airborne science campaign.

The PCIMS instrument is a slightly modified CIMS instrument manufactured by THS Instruments LLC. Mechanically it consists of a differentially pumped quadrupole mass spectrometer. The instrument operates in negative ion mode and currently I^- and O_2^- reagent ions are used to measure hydrogen peroxide and methylhydroperoxide, respectively, by the formation of cluster ions at masses 80 and 161. The reagent ions are produced by flowing a $\text{N}_2/\text{CH}_3\text{I}/\text{O}_2$ mixture past a ^{210}Po foil. The instrument system is laid out in block diagram in Figure 1, which also shows the G-V inlet and calibration configuration.

The PCIMS inlet system starts with a PFA Teflon lined heated G-V HIMIL inlet. From the HIMIL the inlet line is comprised of PFA Teflon and is also heated (Hot-Tube, Clayborn Lab). Analytical blanks are performed by diverting the ambient sample flow through a trap filled with Carulite 200 catalyst. Gas phase calibrations are performed through standard additions to ambient air. H_2O_2 is added from a urea hydrogen peroxide solid decomposition source or by the evaporation of a nano-fluidic flow of a dilute aqueous solution. CH_3OOH is added by the evaporation of a nano-fluidic flow of a dilute aqueous solution. The ambient, calibration and reagent gases are vented overboard through the G-V common exhaust.

The PCIMS analytical system is nearly fully automated. Basic instrument modes for sampling and calibration (blank or standard addition) are automated but an operator is needed for start-up, shut-down and mode changes in-flight. Pre-flight, a dedicated PCIMS operator starts the instrument and its data acquisition and control system. In-flight, PCIMS performance is monitored by an on-board operator shared between multiple instruments. Further, instrument status and data will be transmitted to a dedicated ground operator using the G-V's intranet, data system, and air-ground satellite communications system. The ground operator has the ability to enact changes to the instruments mode of operation in response to the flight plan and measurement targets-of-opportunity identified by the science team during the course of the flight.

Field measured precision, detection limit, and time resolution are to be determined. The anticipated results from the PCIMS instrument are 10 Hz measurements of a specific m/z ion. Depending upon the total number of m/z ions monitored, approximately one 10 Hz measurement will be made once per second. Based upon the test flight in May 2011 and laboratory work since then, we have achieved H_2O_2 and CH_3OOH detection limits (3 times the standard deviation of a 1-min blank at each mass) of 11 and 10 ppt, respectively.

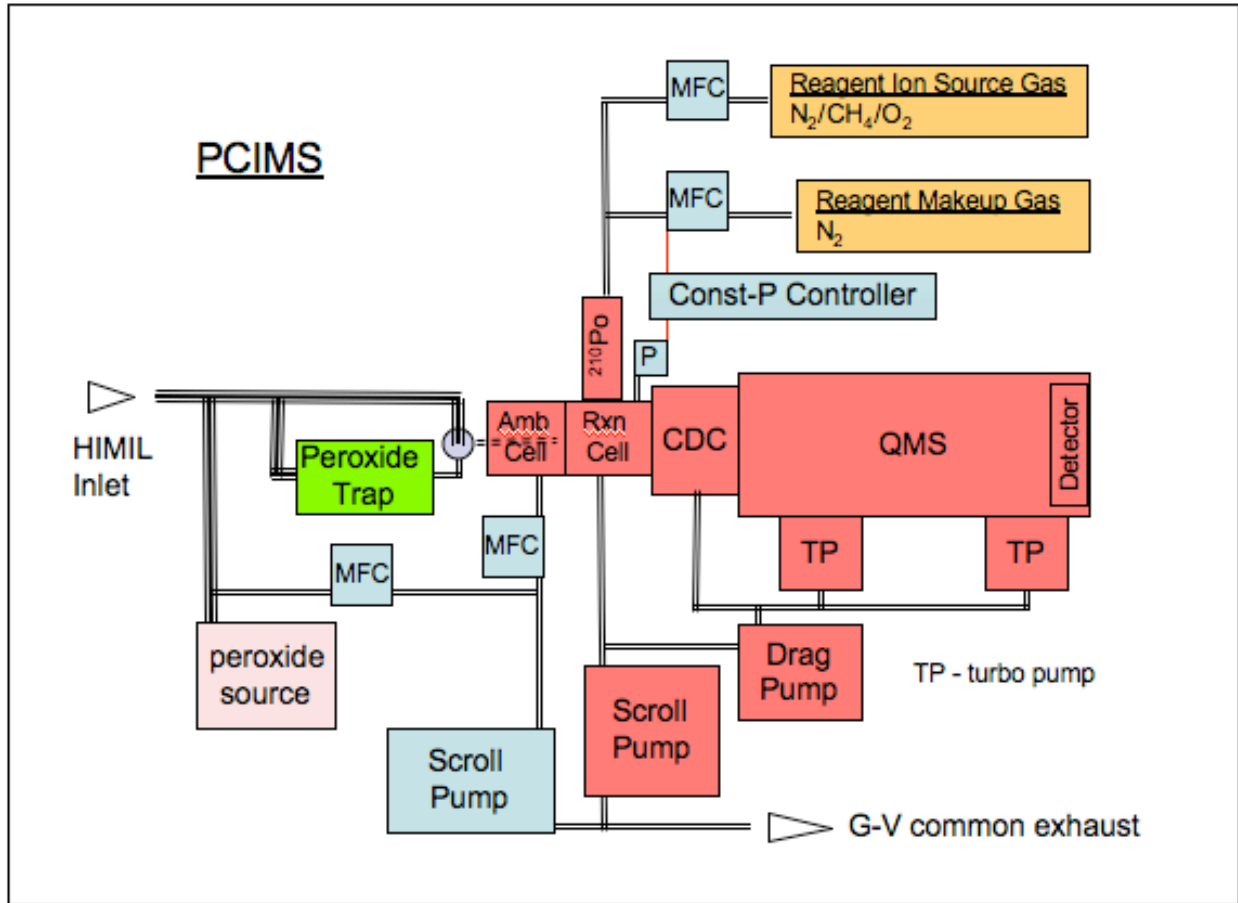

Figure 1. PCIMS instrument schematic and G-V sample and calibration inlet system. An excess of ambient air enters the HIMIL sample inlet and is drawn through a heated inlet to the PCIMS where a portion of the sample air passes through a critical orifice reduced in pressure and mixed with the reagent ion stream. The excess sample is vent overboard. The sample-reagent ion streams are allowed to react and form cluster ions, which pass through a second orifice and filtered using an octopole “collision dissociation chamber”, and ultimately passed to the front end of a quadrupole mass spectrometer after which ions of selected m/z are counted. Periodically, the sample air stream passes through a peroxide trap for analytical blanks or has a known amount of peroxide gas added to it for sensitivity calibration. MFC indicates a mass flow controller.