

# ERICA (ERC Instrument for Chemical composition of Aerosols)

**Principal Investigator:** Stephan Borrmann (stephan.borrmann@mpic.de)

**Co-Investigators:** Franziska Köllner, Oliver Appel, Oliver Eppers, Philipp Brauner, Sergej Molleker, Antonis Dragoneas, Andreas Hünig

**Organization:** Max Planck Institute for Chemistry  
Particle Chemistry Department  
55128 Mainz  
GERMANY

## General Description

The novel aerosol mass spectrometer ERICA (ERC Instrument for Chemical composition of Aerosols) combines two well-established methods of real-time in-situ measurements of aerosol particle chemical composition (Hünig et al., 2022; Dragoneas et al., 2022): The first method is the laser desorption ionization technique of single particles followed by time-of-flight mass spectrometry. The second method is the thermal desorption with subsequent electron impact ionization as implemented in the Aerodyne aerosol mass spectrometer (AMS). The measurement principle is as follows:

The sampled air containing the aerosol particles is injected through a constant pressure inlet (Molleker et al., 2020) into the instrument. The aerosol particles are focused by means of an aerodynamic lens to a narrow beam and accelerated into the vacuum chamber. In the first part of the instrument (ERICA-LAMS), the detection and sizing of individual particles takes place. For this purpose, the incoming particles pass two parallel orientated continuous wave laser beams. At each laser, the light is scattered by each individual particle and focused by an ellipsoidal mirror onto a photomultiplier tube (PMT). By the time elapsing between the two scattered light signals, the vacuum aerodynamic diameter  $d_{va}$  of the particles is derived by using a calibration with particles of known size, density and shape (e.g., polystyrene latex (PSL) particles). After optical detection, the particles enter the mass spectrometer chamber of the ERICA-LAMS, where a triggered 266-nm UV pulse from a frequency-quadrupled Nd:YAG laser vaporizes and ionizes the sized particles. The resulting cations and anions are accelerated into a bipolar time-of-flight mass spectrometer (B-ToF-MS) and detected by micro-channel plates (MCPs). The maximum repetition rate of the ablation laser is 8 pulses per second, thus, the vast majority of particles continue flying downstream without getting hit by the laser. These unablated particles pass through the ionization region of the ERICA-LAMS and enter the second part of the instrument, the continuously operating ERICA-AMS. Here, in analogy to the Aerodyne AMS principle (Canagaratna et al., 2007), they hit a tungsten vaporizer, where the non-refractory components are evaporated at around 600 °C. A filament provides electrons (70 eV) for electron impact ionization of the vapor molecules emanating from the vaporizer. The generated cations are injected into a compact time-of-flight mass spectrometer (C-ToF-MS, Tofwerk AG, Switzerland) and eventually detected by its MCPs. The size range for particle detection in the ERICA-AMS is assumed to be the same as published in Xu et al. (2017) for the deployed aerodynamic lens type ranging from particle diameters of 120 nm to 3.5  $\mu\text{m}$  ( $d_{50}$  cutoff diameters). The lower  $d_{50}$  cutoff diameter for the ERICA-LAMS is limited by the optical detection efficiency to 180 nm.

## Scheme

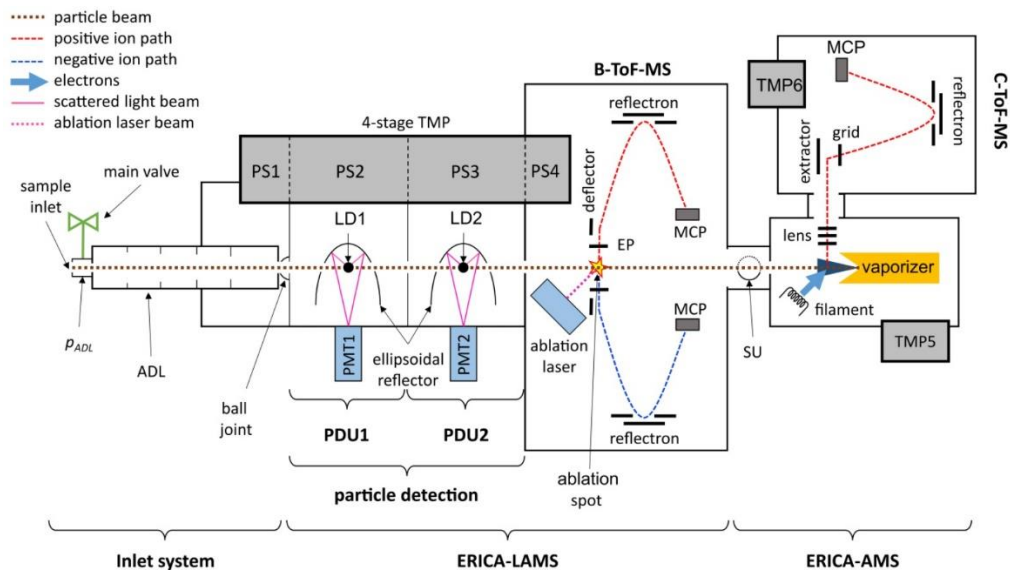

Fig.1: Schematic overview of ERICA (adapted from Hünig et al., 2021)

## Data products:

ERICA-LAMS: Particle size and chemical composition (bipolar mass spectra) of individual aerosol particles

ERICA-AMS: Mass concentrations of different non-refractory compounds contained in aerosol particles (e.g., sulfate, nitrate, organics)

## Specifications for ACCLIP

For ACCLIP, a novel approach will be implemented to obtain quantitative information about single particle chemical composition. This will be achieved by using the optical trigger from the ERICA-LAMS detection stages to determine the particle arrival time in the ERICA-AMS. Consequently, this optically-triggered AMS (OT-AMS) mode will provide mass spectra of non-refractory components from individual particles in addition to the bulk particle information. In addition, an impactor is installed inside the ERICA rack to collect aerosol particles for a posteriori analyses in the laboratory.

## References

Canagaratna, et al.: Chemical and microphysical characterization of ambient aerosols with the aerodyne aerosol mass spectrometer, *Mass Spectrom. Rev.*, 26, 185-222, DOI: 10.1002/mas.20115, 2007.

Dragoneas, A. et al.: The realization of autonomous, aircraft-based, real-time aerosol mass spectrometry in the upper troposphere and lower stratosphere, *EGUsphere* [preprint], DOI: 10.5194/egusphere-2022-33, 2022.

Hünig, A. et al.: Design, characterization, and first field deployment of a novel aircraft-based aerosol mass spectrometer combining the laser ablation and flash vaporization techniques, *Atmos. Meas. Tech.*, 15, 2889–2921, DOI: 10.5194/amt-15-2889-2022, 2022.

Molleker, S. et al.: Application of an O-ring pinch device as a constant-pressure inlet (CPI) for airborne sampling, *Atmos. Meas. Tech.*, 13, 3651–3660, DOI: 10.5194/amt-13-3651-2020, 2020.

Xu, W. et al.: Laboratory characterization of an aerosol chemical speciation monitor with PM<sub>2.5</sub> measurement capability, *Aerosol Science and Technology*, 51:1, 69-83, DOI: 10.1080/02786826.2016.1241859, 2017.